

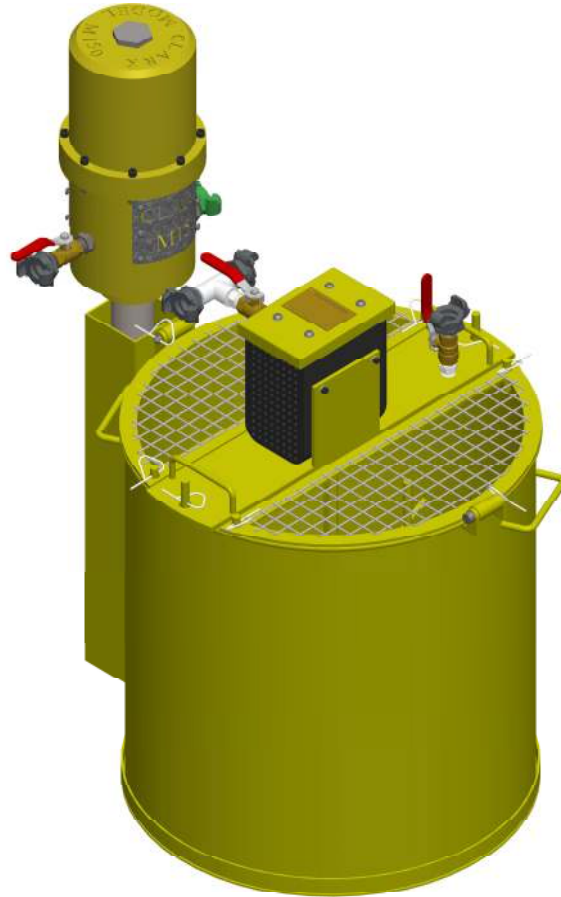

# CLARK GROUT PUMPS AND MIXERS

Product Data Sheet



Left: Standard M150 grout pump and 150 litre mixer with Eagle Mk2 air powered mixer motor

## Clark Grout Pumps and Mixers

The pneumatic range of Clark Grout Pump and Mixers have been used in coal mining and civil construction applications for more than twenty years. The grout pump can be utilized for various applications. These include: pressure injection of cable bolts for roof and strata support; void filling of strata, either to atmosphere or injected with the Clark grout packer; spraying of ventilation stoppings in coal mines; spraying concrete on pylons and bridge repairs and also slab jacking.

The grout pump options can be used in combination with the Clark Grout Mixers. Two different capacity mixers are available. The 150 litre capacity mixer is the most common size for easy handling in confined areas. For larger mixes, the 500 litre capacity mixers yield around 300 litres of grout per batch and have been used in many civil construction applications such as the strengthening of Sydney Airport runway.

For underground coal applications such as cable bolting using Stratabinder or similar type grout, the M150 with the Mk2 mixer is recommended.

For thicker grouts such as thixotropic grouts, the M150 with a thixotropic mixer is preferred.

### Applications:

- Cable bolting
- Spraying
- Void filling
- Slab jacking

### Associated Clark products:

- Grout spray gun
- Drill rig
- Eagle Rib drill
- Grout packer
- Grout and air hose
- Lubricator

### Options:

- 150 or 500 litre capacities
- Thixotropic bowl or flat bottom
- Standard or high torque mixer
- Standard flow or high flow pump



*Designers and  
manufacturers of  
mining and construction  
equipment*

A.B.N. 42 050 287 173 | A.C.N. 050 287 173

### SALES

ph. 612 4272 8311  
fx. 612 4272 8533  
30 Waverley Drive  
Unanderra NSW 2526  
cmsadmin@bigpond.com

### ACCOUNTS

ph. 612 4271 4036  
fx. 612 4271 4015  
30 Waverley Drive  
Unanderra NSW 2526  
clarksmineaccounts@bigpond.com

[www.clarksmineingservices.com.au](http://www.clarksmineingservices.com.au)

[gou.gl/qOoy4K](https://www.youtube.com/watch?v=qOoy4K)



# CLARK GROUT PUMP MODELS

## Product Data Sheet



M150P



M150



M150EQ



M150CAM



M150EQCAM

	M150P	M150	M150EQ
Motor Piston Ømm	150	150	150
Weight kg	16.6	17	19
Length mm	1056	1090	1095
Maximum Flow l/min	20	60	110
Maximum Pressure kPa	5100	3500	1900
Maximum air supply m <sup>3</sup> /h	50	50	50
Discharge Port mm BSP	25	25	40

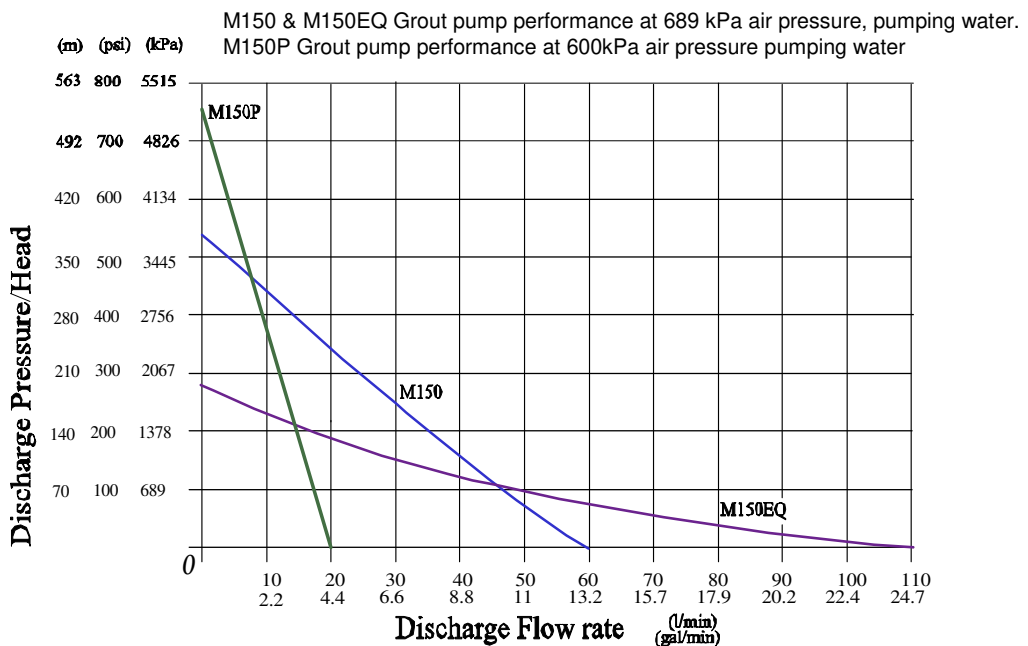

Designers and manufacturers of mining and construction equipment

A.B.N. 42 050 287 173 | A.C.N. 050 287 173

### SALES

ph. 612 4272 8311  
 fx. 612 4272 8533  
 30 Waverley Drive  
 Unanderra NSW 2526  
 cmsadmin@bigpond.com

### ACCOUNTS

ph. 612 4271 4036  
 fx. 612 4271 4015  
 30 Waverley Drive  
 Unanderra NSW 2526  
 clarksmineaccounts@bigpond.com



# CLARK GROUT MIXER MODELS

## Product Data Sheet

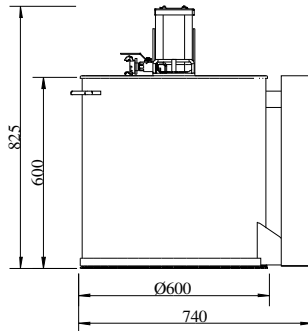

### 01 GP 406 MK2 MIXER

Capacity: 150Litre  
Flat bottom  
RPM: 1200  
Starting Torque:27Nm  
Air Consumption: 37 l/sec  
Use with Clark Grout Pump:  
M100, M150 or M150EQ  
Weight 42kg

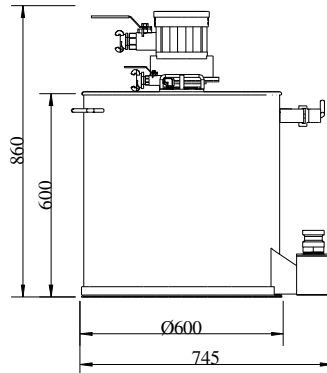

### 01 GP 408 THIXO MIXER CAM

Capacity: 150Litre  
Dome Base – cam lock suction  
RPM: 600  
Starting Torque:225Nm  
Air Consumption: 120 l/sec  
Use with Clark Grout Pump:  
M150cam or M150EQcam  
Weight 60kg

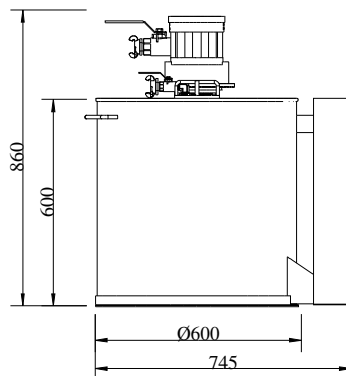
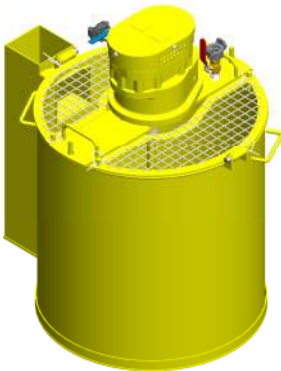

### 01 GP 490 THIXO MIXER

Capacity: 150Litre  
Dome Base  
RPM: 600  
Starting Torque:225Nm  
Air Consumption: 120 l/sec  
Use with Clark Grout Pump:  
M100, M150 or M150EQ  
Weight 62kg

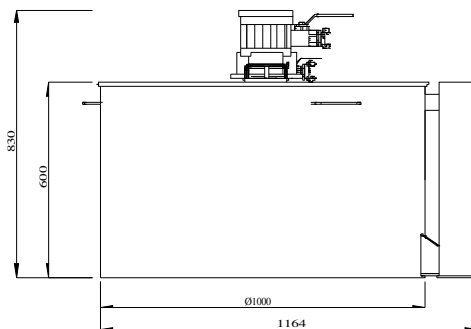
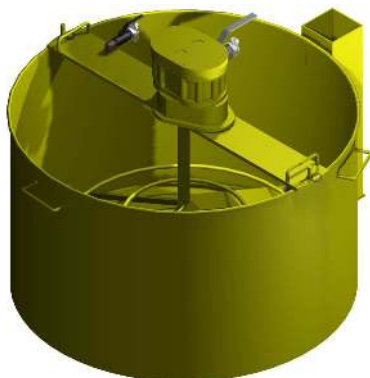

### 01 GP 900 THIXO MIXER

Capacity: 500Litre  
Dome Base  
RPM: 600  
Starting Torque:225Nm  
Air Consumption: 120 l/sec  
Use with Clark Grout Pump  
M100, M150 or M150EQ  
Weight 80kg



*Designers and  
manufacturers of  
mining and construction  
equipment*

A.B.N. 42 050 287 173 | A.C.N. 050 287 173

#### SALES

ph. 612 4272 8311  
fx. 612 4272 8533  
30 Waverley Drive  
Unanderra NSW 2526  
cmsadmin@bigpond.com

#### ACCOUNTS

ph. 612 4271 4036  
fx. 612 4271 4015  
30 Waverley Drive  
Unanderra NSW 2526  
clarksmineaccounts@bigpond.com



# CLARK GROUTING ESSENTIALS

Product Specification Sheet



## Air Line Lubricator

Part # 05 MIN 20  
Adjustable jet  
Steel body  
1.25 litre capacity



## Hose assembly air and delivery

Part # 24HG002 FRAS AIR HOSE 20m, 20bar (300psi)  
Part # 24HG007 FRAS AIR HOSE 1m, 20bar (300psi)  
Part # 24HG011 FRAS AIR/WATER HOSE 20m, 35bar (525psi)

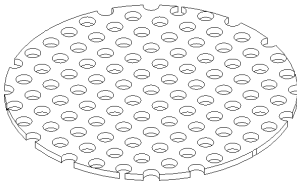

## Filter discs

Part# 06AL00  
Fits inside air hose coupling to filter out dirt



## Safety clips

05MIN49  
Used to retain snap couplings on hoses



*Designers and  
manufacturers of  
mining and construction  
equipment*

A.B.N. 42 050 287 173 | A.C.N. 050 287 173

### SALES

**ph.** 612 4272 8311  
**fx.** 612 4272 8533  
30 Waverley Drive  
Unanderra NSW 2526  
cmsadmin@bigpond.com

### ACCOUNTS

**ph.** 612 4271 4036  
**fx.** 612 4271 4015  
30 Waverley Drive  
Unanderra NSW 2526  
clarksmineaccounts@bigpond.com

[www.clarksmineingservices.com.au](http://www.clarksmineingservices.com.au)

[goo.gl/qOoy4K](https://www.youtube.com/watch?v=qOoy4K)





# CLARK MIXER SCREEN GUARDS

Product Data Sheet

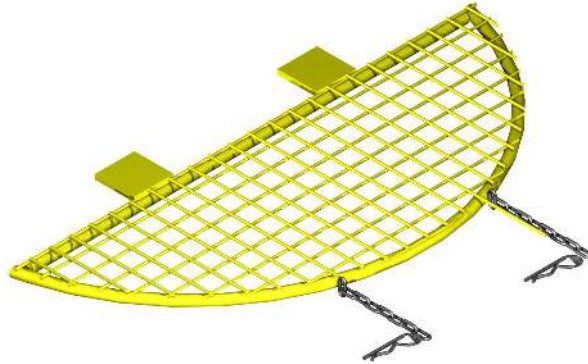

Screen guard suit 150L mixers part # 01 GP 482  
Screen guard suit 500L mixers part # 01 GP 919

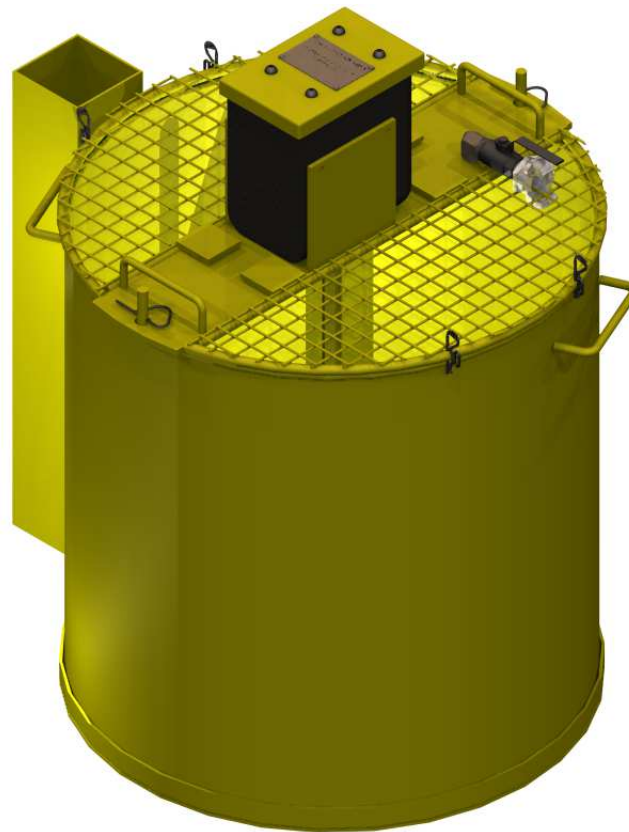

01 GP 406 mixer with two screen guards fitted  
Guards supplied as standard from March 2017



*Designers and  
manufacturers of  
mining and construction  
equipment*

A.B.N. 42 050 287 173 | A.C.N. 050 287 173

#### SALES

ph. 612 4272 8311  
fx. 612 4272 8533  
30 Waverley Drive  
Unanderra NSW 2526  
cmsadmin@bigpond.com

#### ACCOUNTS

ph. 612 4271 4036  
fx. 612 4271 4015  
30 Waverley Drive  
Unanderra NSW 2526  
clarksmineaccounts@bigpond.com

[www.clarksmineingservices.com.au](http://www.clarksmineingservices.com.au)

[▶ goo.gl/qOoy4K](https://www.youtube.com/watch?v=qOoy4K)